

Direct Airscale

easy series



Code : from 1835 to 1866

TECHNICAL INSTRUCTIONS

May change without notice



First 162

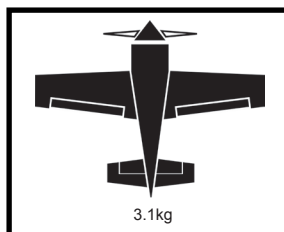
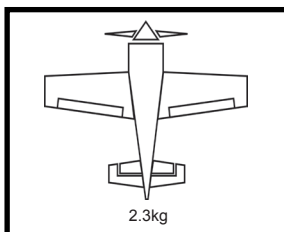
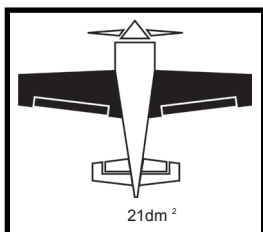
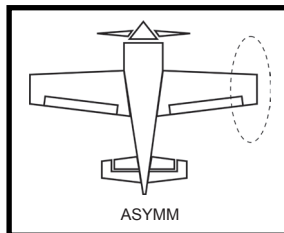
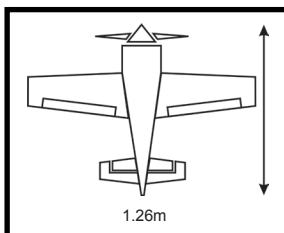
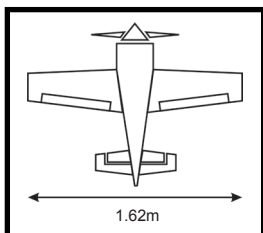

SERVOS

- Ailerons
- Rudder + wheel
- Elevator
- Flaps
- Landing gear
- Gas or bec

CONGRATULATIONS.

Thank you for choosing *Direct Airscale* model. If you have any problems do not hesitate to consult our website. Especially the section **CLUB DA** (Direct Airscale club) for each plane where you will find information. You also can consult us directly by phone but try to be a maximum shorter 😊. Thank you. You also can participate in the interaction you'll find at general chapter **CLUB DA**.

The first (your first one) is the specific airplane for beginner. Rectangular wing with lift wing edge. Moderate dihedral. Good ratio length / size (0.78) for a good pitch tolerance and easy balancing. Tricycle landing gear to protect the propeller in case of scabrous land return. Large diameter wheels for tracks average on bumpy land. High wing for a natural tendency to return to horizontal. Logo **DA** (direct airscale) very visible to the underside (below) for tracking even from a distance knowing that beginners tend to leave "escape" their planes 😊.

At the request of many experienced instructors despite that "tradition" requires a flat profile to the underside for beginner aircraft, we assigned an asymmetric biconvex profile our firsts for a lesser influence of wind or changes in engine speed. Obviously a 3 axes concept (with ailerons) was necessary so that the behavior is educationally significant under your thumbs.

WARNING

If you are inexperienced with basic r/c flight we strongly recommended you contact the nearest model aircraft club. Experienced members will help you to install additional accessories to put your aircraft airworthy. The club will ensure your training and you will avoid flying illegally and destroy your aircraft from the first flight.

ADDITIONAL ITEMS REQUIRED.

- Propulsion set depending your choice : gas or electric.
- Radio set minimum 4 channels.
- 4 servos.
- Propeller.
- Electric lipo pack or Ni-Mh.
- Switch or Bec controller and fuse.

TOOLS AND SUPPLIES.

- Thick cyanoacrylate glue.
- 30 minute epoxy.
- Electric drill.
- Assorted drill bits.
- Modelling knife.
- Straight ruler.
- Miscellaneous sandpaper.
- 90° builder's triangle.
- Wire cutters.
- Tape & T-pin
- A set of small keys 6 section
- A set of screw drivers

KIT CONTAIN.

- Light and rigid balsa and plywood construction
- Hull and wings constructed and covered
- Rigid aluminium landing gear
- Large wheels diameter
- Controlled front wheel
- Spinner
- Gas engine accessories (tank, engine mount,...)
- Electric engine accessories (wooden part for lipo, mounting kit,...)
- All necessary hardware and accessories included
- Document for assembly (Several languages).

HINGING THE AILERON.

Note : The control surfaces, including the ailerons, elevators, and rudder, are pre-hinged with hinges in stalled, but the hinges are not glued in place. It is imperative that you properly adhere the hinges in place per the steps that follow using a high-quality thin C/A glue.

- 1) Carefully remove the aileron from one of the wing panels. Note the position of the hinges.

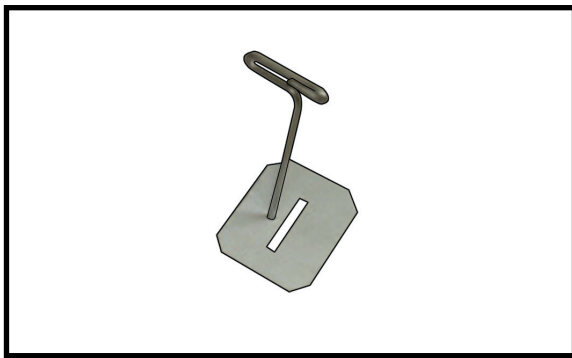

- 2) Remove each hinge from the wing panel and aileron and place a T-pin in the center of each hinge. Slide each hinge into the aileron until the T-pin is snug against the aileron. This will help ensure an equal amount of hinge is on either side of the hinge line when the aileron is mounted to the wing panel.

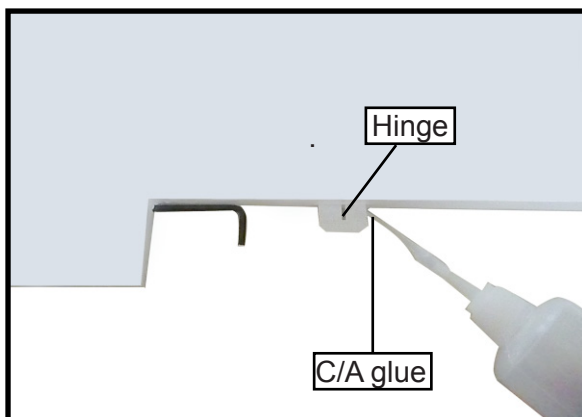

- 3) Slide the aileron on the wing panel until there is only a slight gap. The hinge is now centered on the wing panel and aileron. Remove the T-pins and snug the aileron against the wing panel. A gap of 1/64" or less should be maintained between the wing panel and aileron.

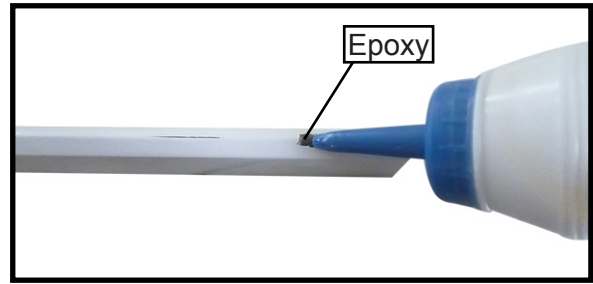

- 4) Deflect the aileron and completely saturate each hinge with thin C/A glue. The ailerons front surface should lightly contact the wing during this procedure. Ideally, when the hinges are glued in place, a 1/64" gap or less will be maintained throughout the length of the aileron to the wing panel hinge line.

Note : The hinge is constructed of a special material that allows the C/A to wick or penetrate and distribute throughout the hinge, securely bonding it to the wood structure of the wing panel and aileron.

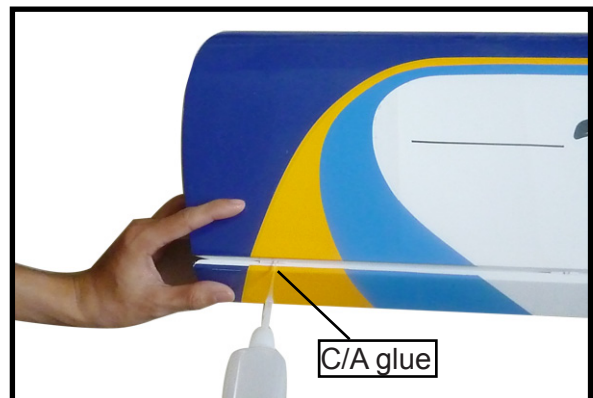
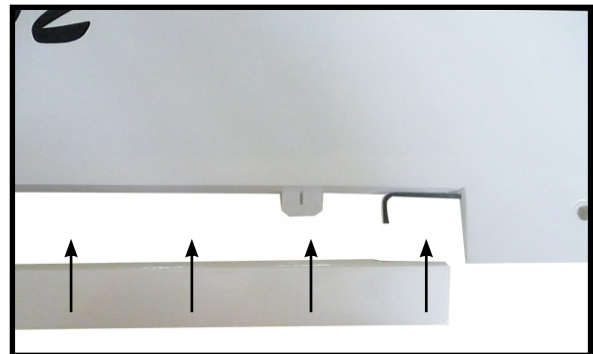



5) Turn the wing panel over and deflect the aileron in the opposite direction from the opposite side. Apply thin C/A glue to each hinge, making sure that the C/A penetrates into both the aileron and wing panel.

6) Using C/A remover/debonder and a paper towel, remove any excess C/A glue that may have accumulated on the wing or in the aileron hinge area.

7) Repeat this process with the other wing panel, securely hinging the aileron in place.

8) After both ailerons are securely hinged, firmly grasp the wing panel and aileron to make sure the hinges are securely glued and cannot be pulled out. Do this by carefully applying medium pressure, trying to separate the aileron from the wing panel. Use caution not to crush the wing structure.



Note: Work the aileron up and down several times to “work in” the hinges and check for proper movement.

HINGING THE ELEVATOR.

1) Locate the item for this section of the manual.

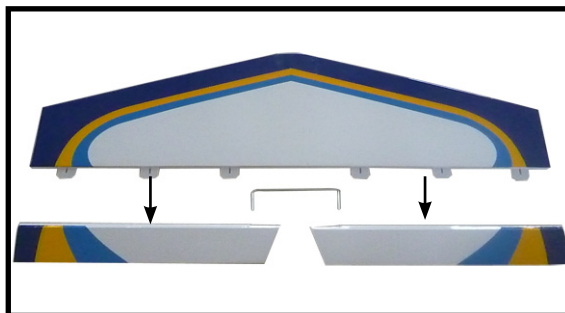

2) Carefully remove the elevator from one of the horizontal stabilizer panels. Note the position of the hinges.

3) Remove each hinge from the horizontal stabilizer panel and elevator and place a Tpin in the center of each hinge. Slide each hinge into the elevator until the T- pin is snug against the elevator. This will help ensure an equal amount of hinge is on either side of the hinge line when the elevator is mounted to the horizontal stabilizer panel.

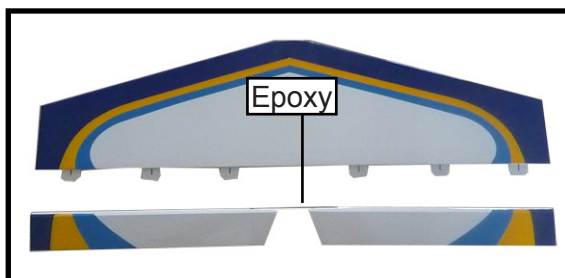

Glue the elevator hinges in place using the same techniques used to hinge the ailerons.

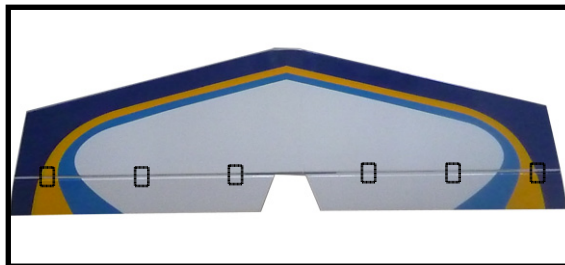

HINGING THE RUDDER.

Glue the rudder hinges in place using the same techniques used to hinge the ailerons.

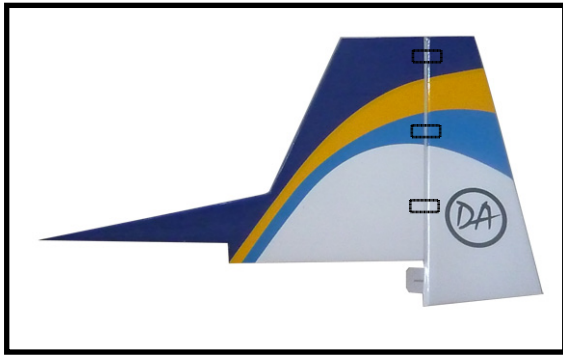

WING ASSEMBLY.

See below pitures.



Aluminium wing tube

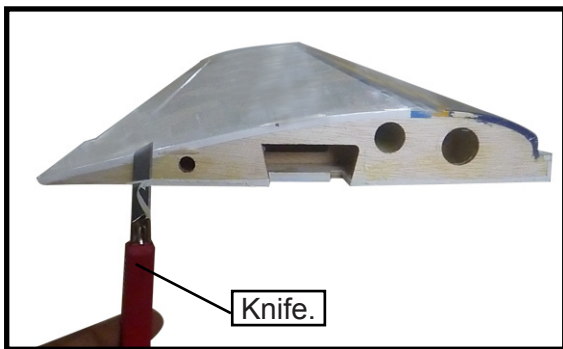

Knife.

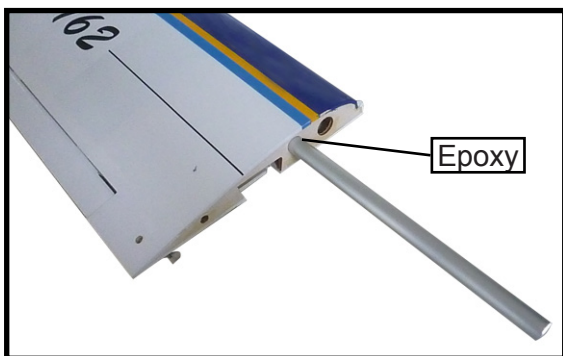

Epoxy

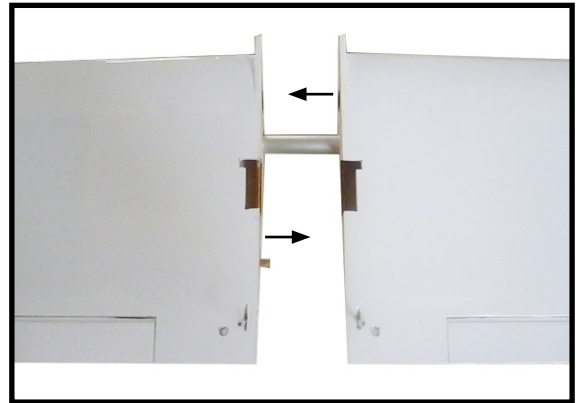
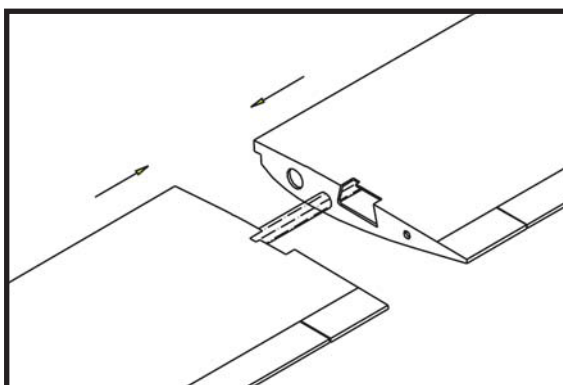

WING ASSEMBLY.

See below pitures.

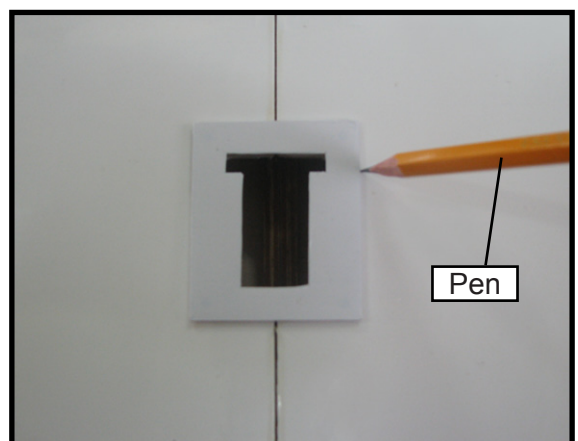
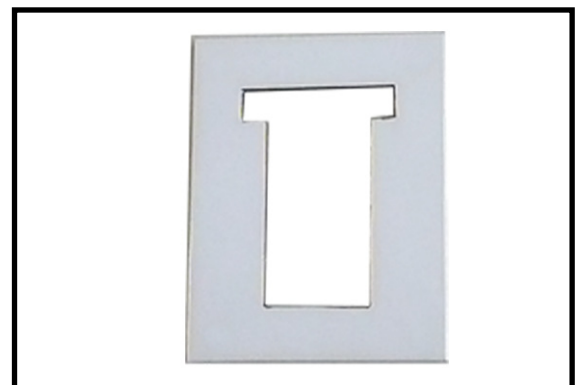

Pen

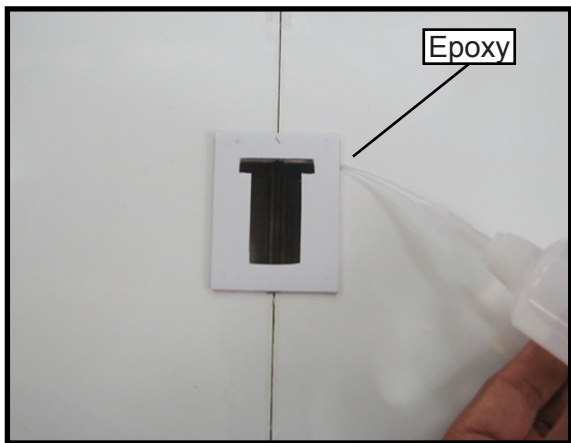
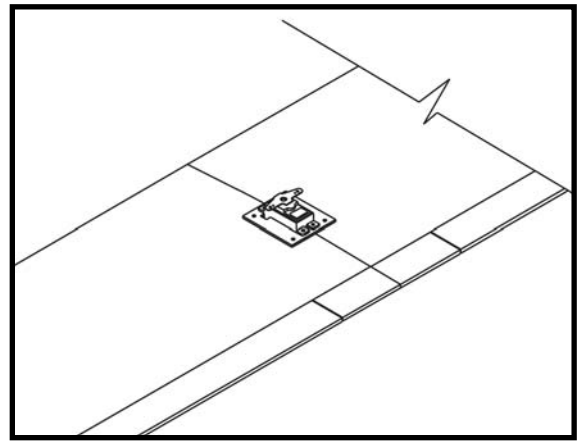
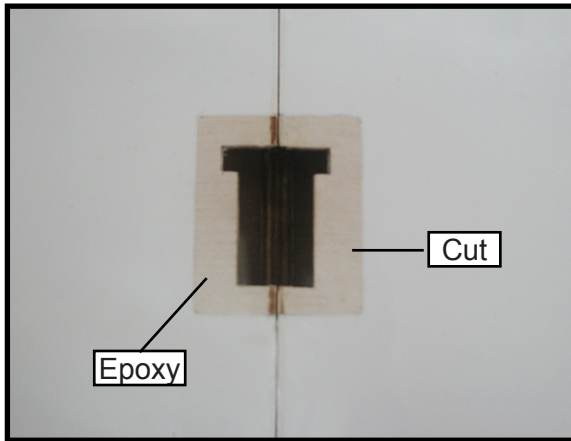

INSTALLING THE AILERON SERVO.

1) Install the aileron servo into the servo-mount, with the output shaft towards the leading edge of the wing, using the wood screws provided with your radio system. Drill 1/16" pilot holes through the mount before installing the screws. This will prevent the wood from splitting.

INSTALLING THE AILERON LINKAGE.

See below pitures.

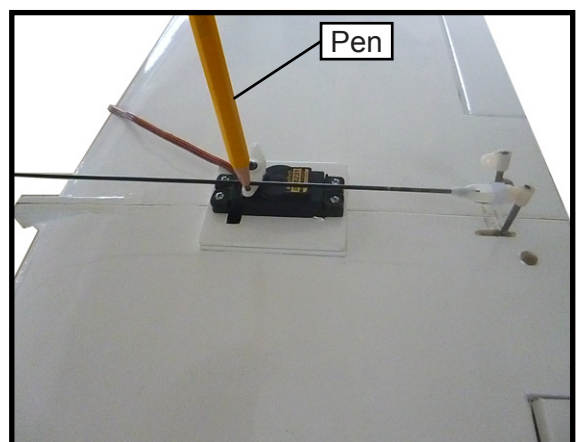
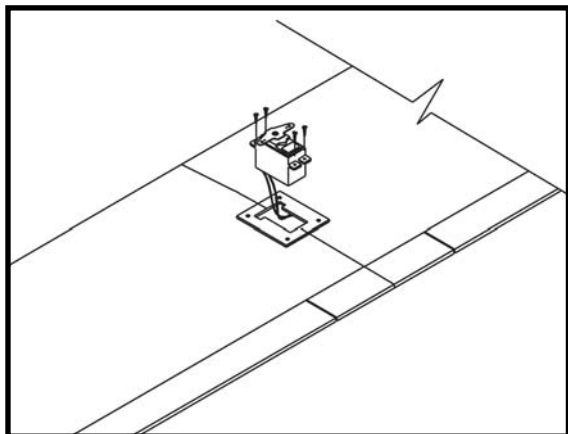

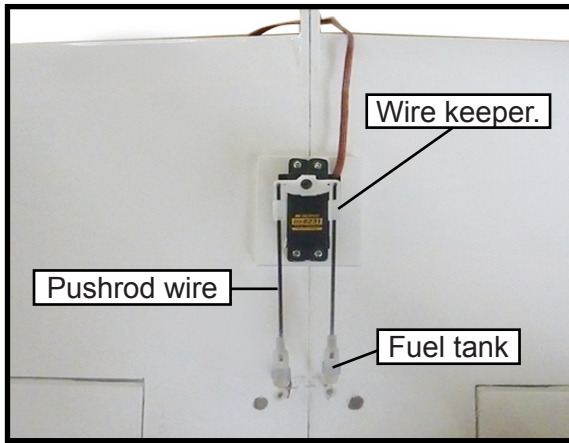

INSTALLING THE LANDING GEAR.

- 1) The blind nuts for securing the landing gear are already mounted inside the fuselage.
- 2) Using the hardware provided, mount the main landing gear to the fuselage.
- 3) Place the fuselage inverted on the work-bench in a suitable stand. Set the landing gear in place and use a screwdriver to secure the landing gear to the fuselage using bolts M4x20mm and washers. Make sure to use the threadlock on the bolts so they don't vibrate loose.

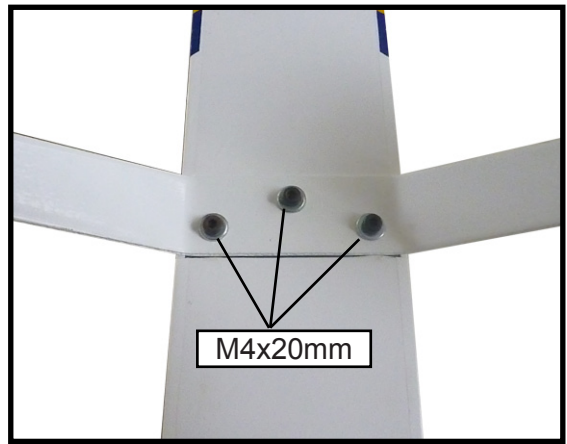
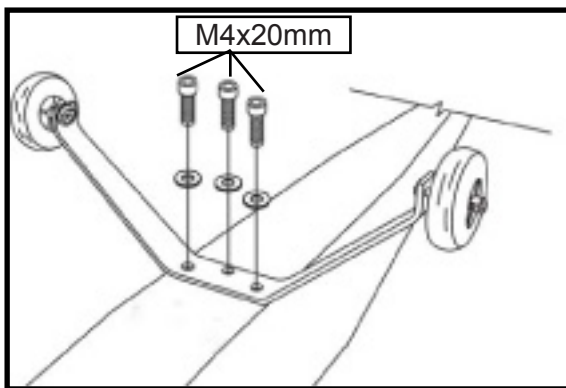

NOSE GEAR INSTALLATION.

See below pictures.

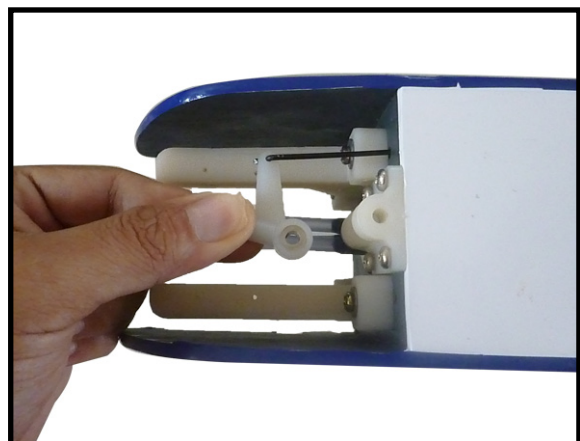
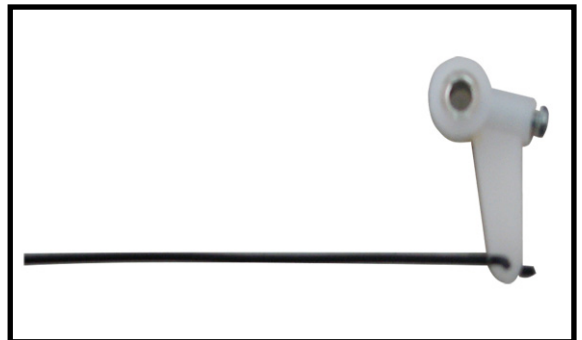
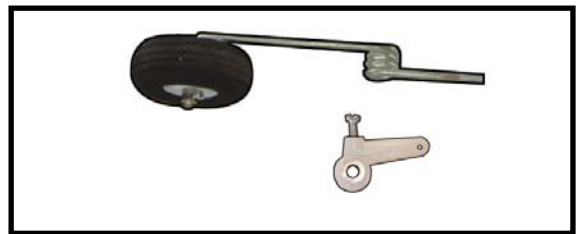

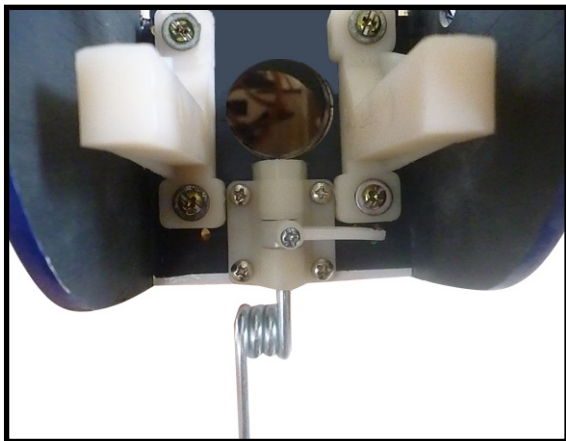

FUEL TANK INSTALLATION.

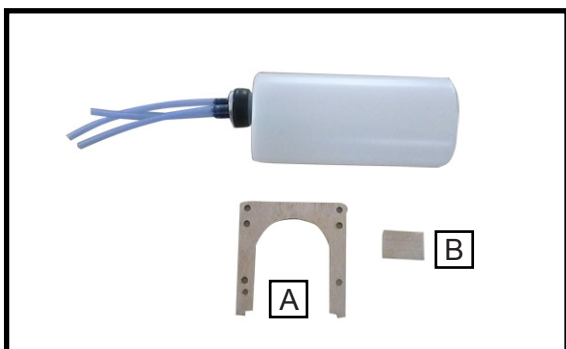

⚠ You should mark which tube is the vent and which is the fuel pickup when you attach fuel tubing to the tubes in the stopper. Once the tank is installed inside the fuselage, it may be difficult to determine which is which

1) Slide the fuel tank into the fuselage. Guide the lines from the tank through the hole in the firewall.

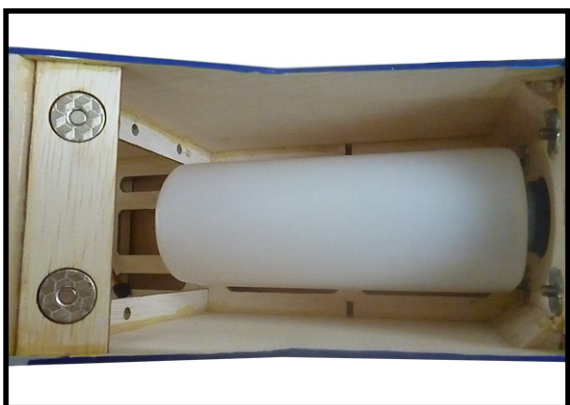

2) Use balsa plywood to help prevent moveable from transferring to the fuel tank as shown.

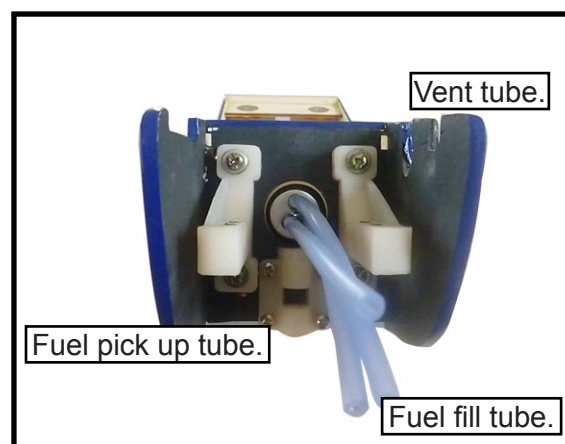
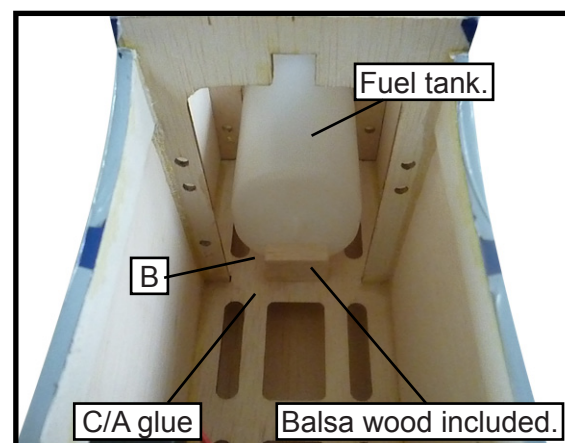
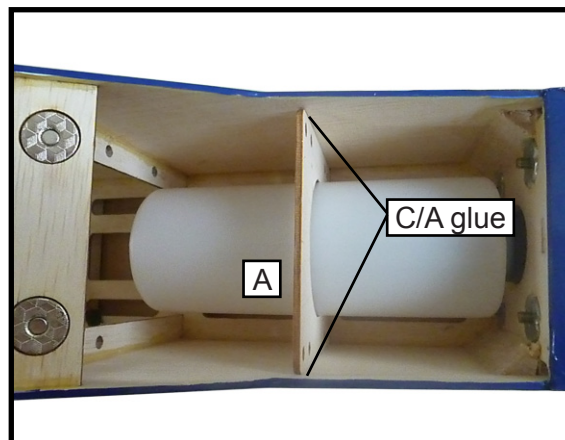

3) Connect the lines from the tank to the engine and muffler. The vent line will connect to the muffler and the line from the clunk to the carburetor.

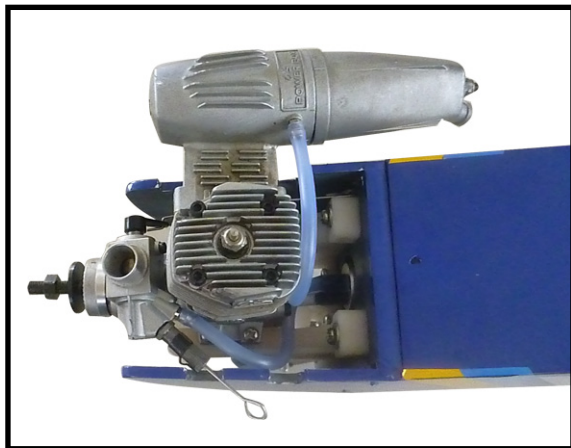

! Blow through one of the lines to ensure the fuel lines have not become kinked inside the fuel tank compartment. Air should flow through easily.

INSTALLING THE FUSELAGE SERVOS.

! Because the size of servos differ, you may need to adjust the size of the precut opening in the mount. The notch in the sides of the mount allow the servo lead to pass through.

1) Install the rubber grommets and brass collets onto the throttle servo. Test fit the servo into the aileron servo mount.

2) Secure the servos with the screws provided with your radio system.

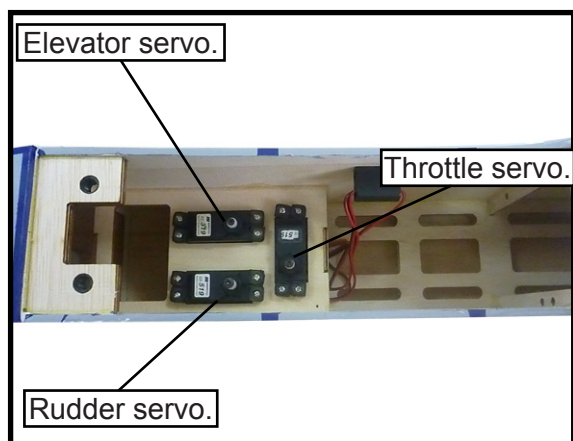

THROTTLE SERVO ARM INSTALLATION.

Install adjustable servo connector in the servo arm as same as picture below:

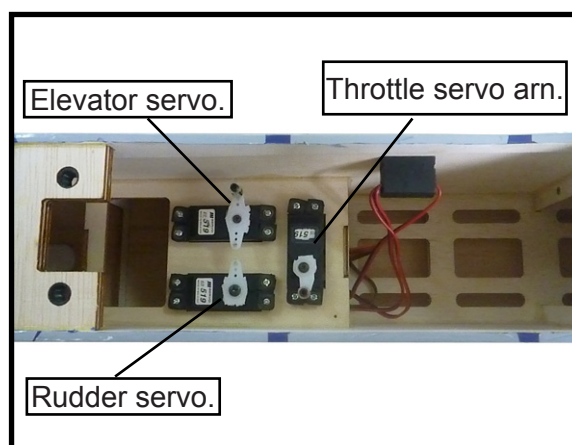
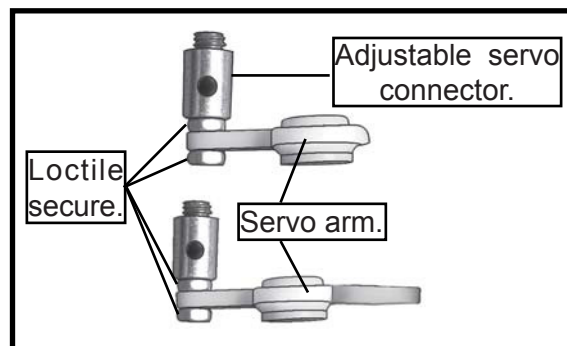

INSTALLING THE SWITCH.

Install the switch into the precut hole in the side, in the fuselage.

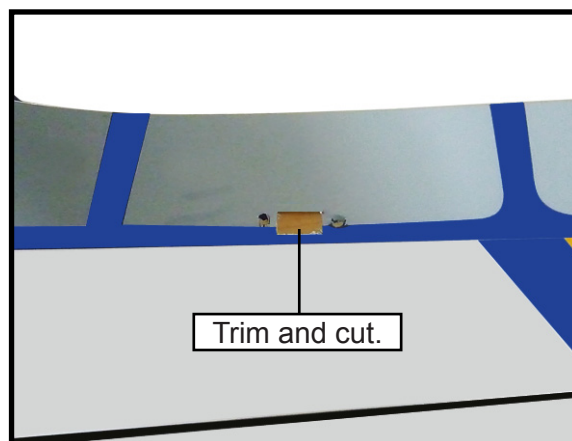
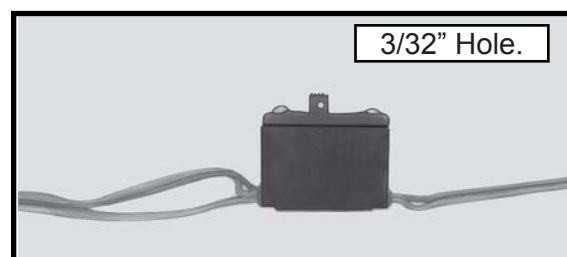

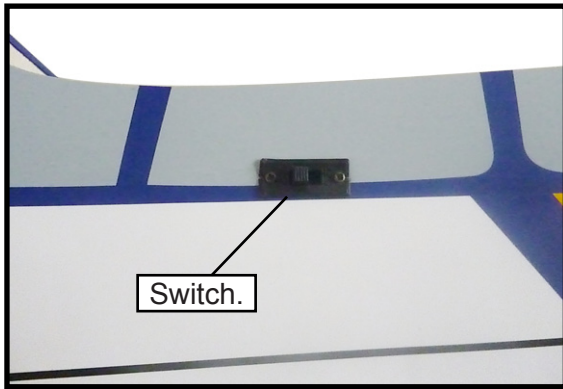

MOUNTING THE ENGINE.

+ ENGINE .46- .55 : 2 STROKE

1) Position the engine with the drive washer (110mm) forward of the firewall as shown.

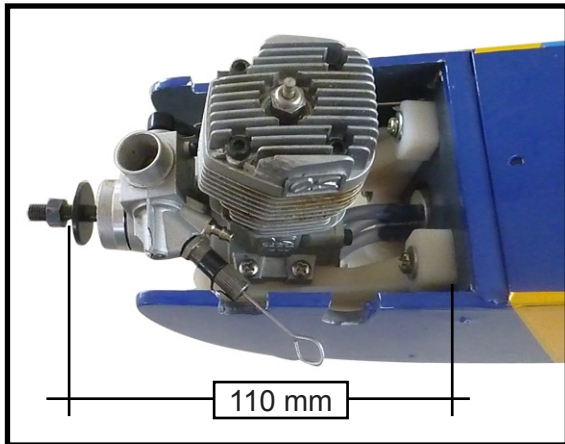

2) Use a pin drill and 2mm drill bit to drill a small indentation in the mount for the engine mounting screw.

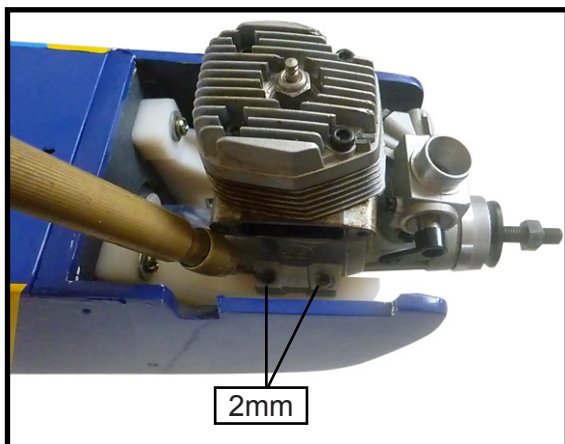

3) Use a drill to drill the four holes in the engine mount rails.

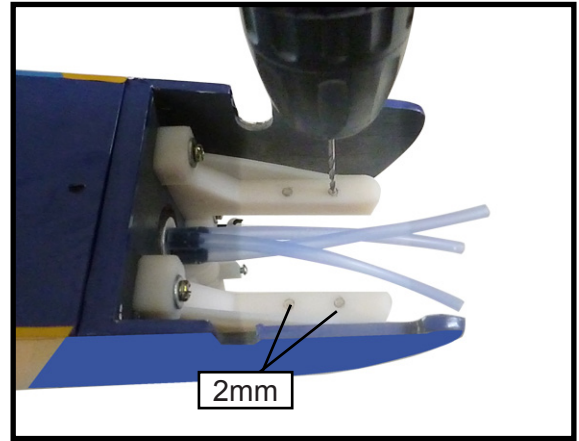

4) On the fire wall has the location for the throttle pushrod tube (pre-drill).

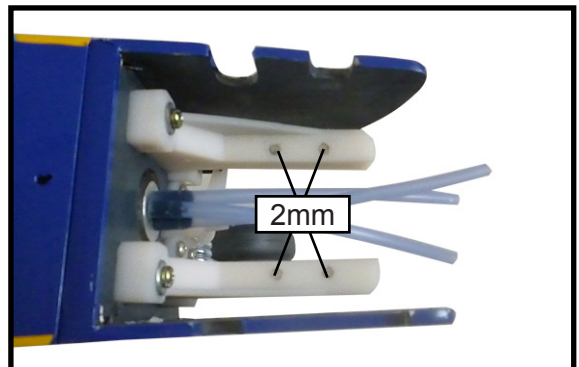

5) Slide the pushrod tube in the firewall and guide it through the fuel tank mount. Use medium C/A to glue the tube to the firewall and the fuel tank mount.

6) Connect the Z-bend in the 450mm throttle pushrod to the outer hole of the carburetor arm.

7) Slide the throttle pushrod wire into the tube. Position the engine between the mounts. Use four M3x25mm machine screws to secure the engine to the mount as shown.

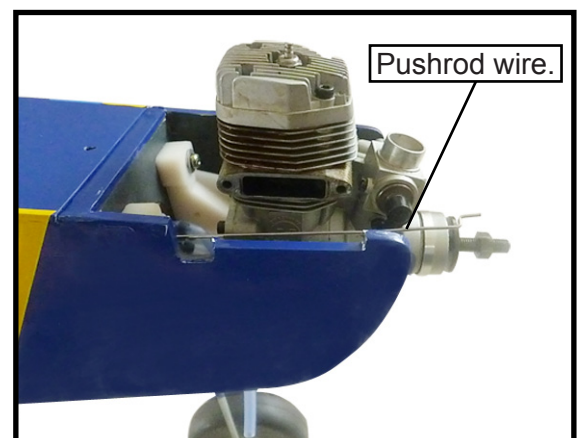

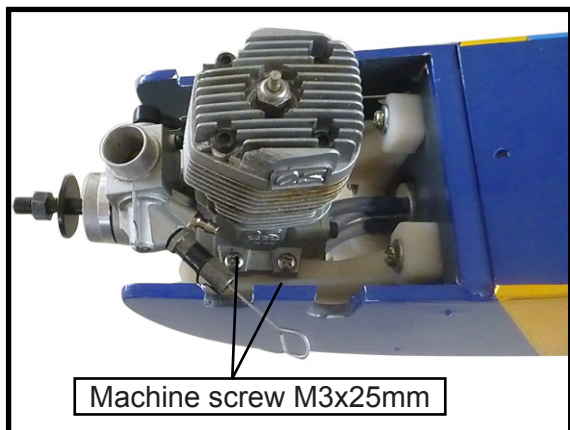

8) Reinstall the servo horn by sliding the connector over the pushrod wire. Center the throttle stick and trim and install the servo horn perpendicular to the servo center line.

9) Move the throttle stick to the closed position and move the carburetor to closed. Use a 2.5mm hex wrench to tighten the screw that secures the throttle pushrod wire. Make sure to use threadlock on the screw so it does not vibrate loose.

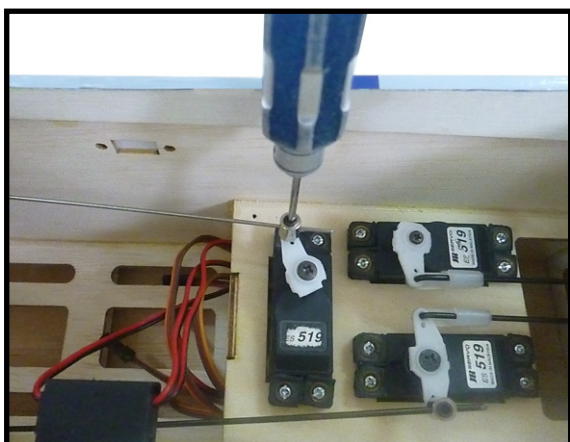

INSTALLING THE SPINNER.

Install the spinner backplate, propeller and spinner cone.



The propeller should not touch any part of the spinner cone. If it does, use a sharp modeling knife and carefully trim away the spinner cone where the propeller comes in contact with it.

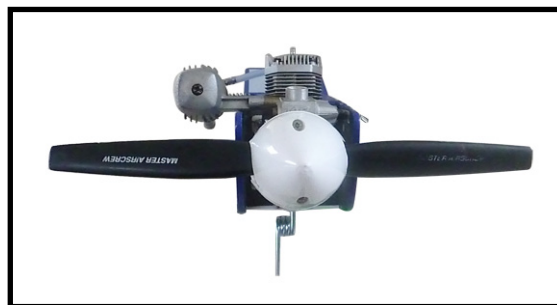

ELECTRIC POWER CONVERSION.

1) Locate the items necessary to install the electric power conversion included with your model.

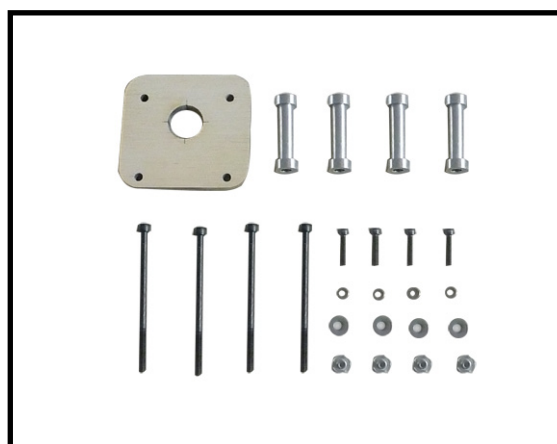

- **Model size:** .46-.52 size models
- **Motor:** 35mm 830 rev per volt
- **Propeller:** 12x 6 - 13x 6
- **ESC:** 60A
- **Lipo Batteries:** 4cell 4200mA

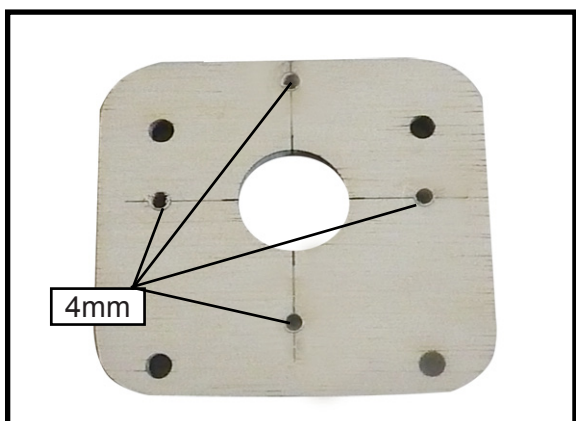
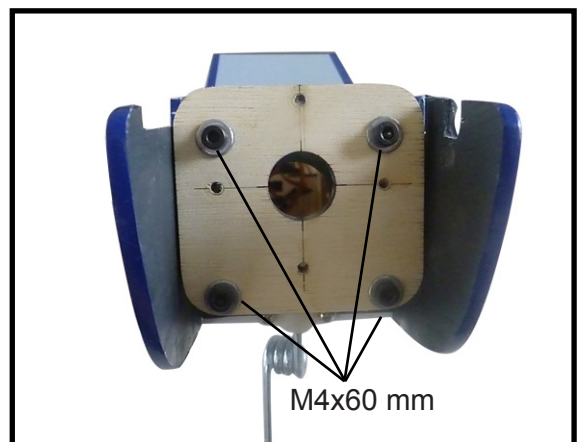
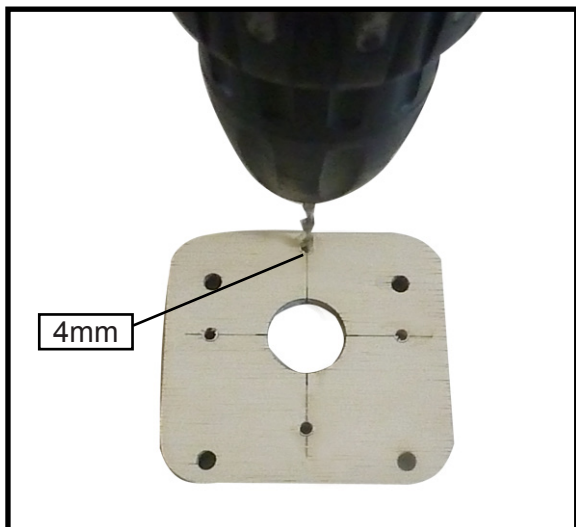
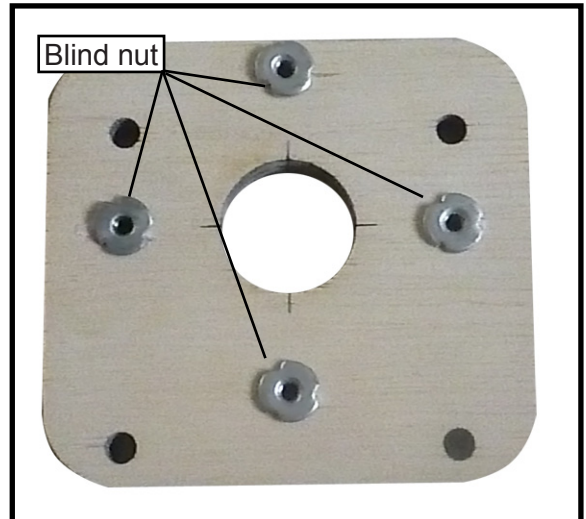
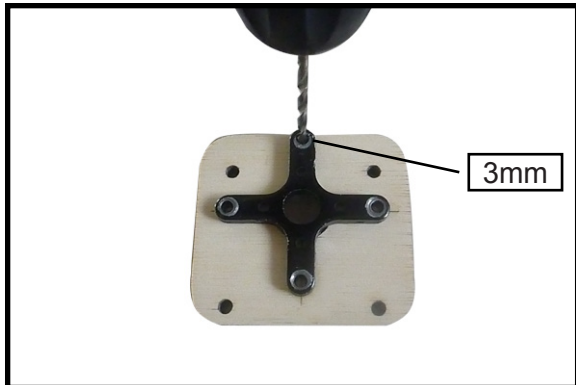
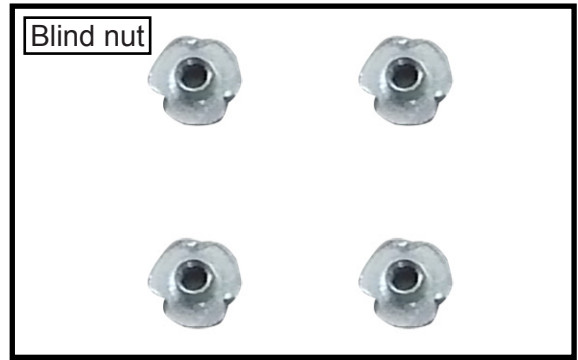
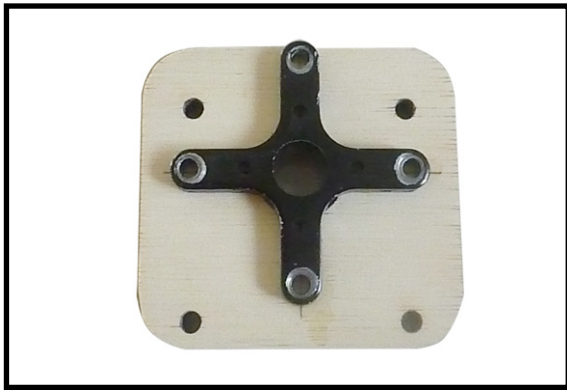

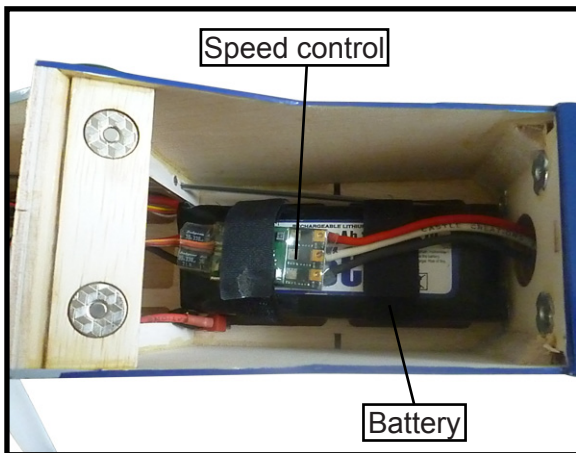
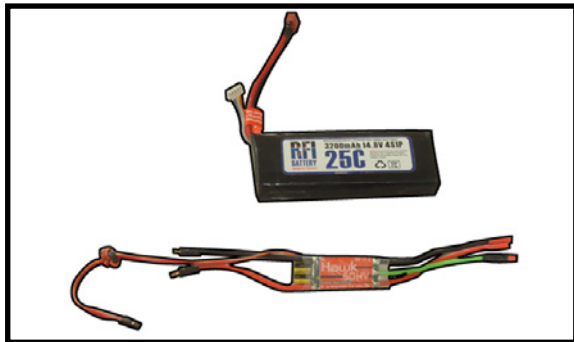
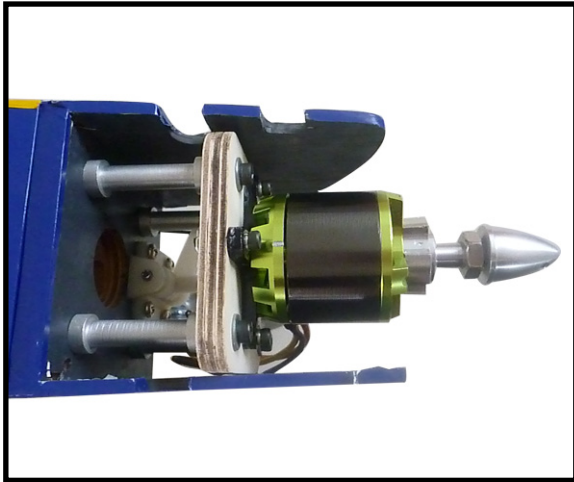

COWLING

1) Slide the fiberglass cowl over the motor and line up the back edge of the cowl with the marks you made on the fuselage then trim and cut as shown.

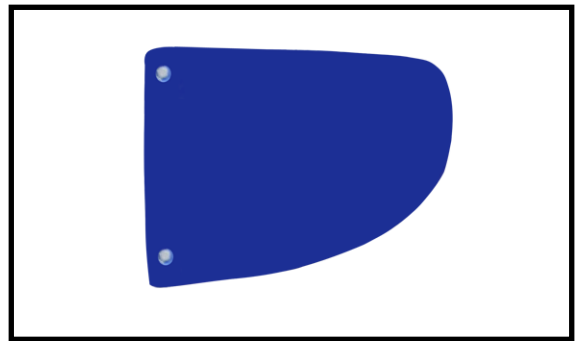
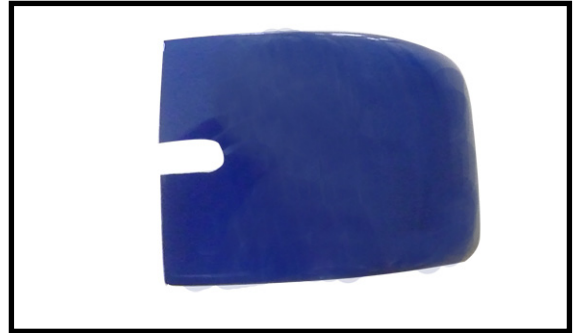

2) While keeping the back edge of the cowl flush with the marks, align the front of the cowl with the crankshaft of the engine. The front of the cowl should be positioned so the crankshaft is in nearly the middle of the cowl opening. Use the spinner backplate as a guide. Hold the cowl firmly in place using pieces of masking tape.



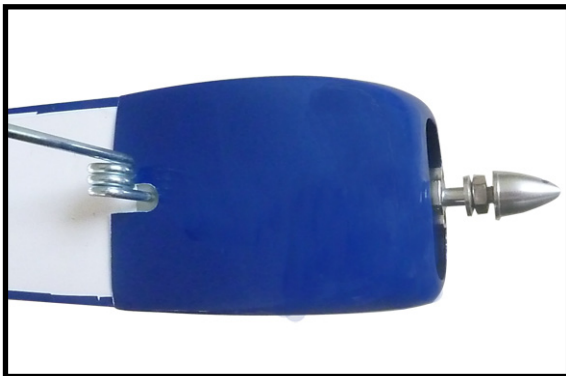
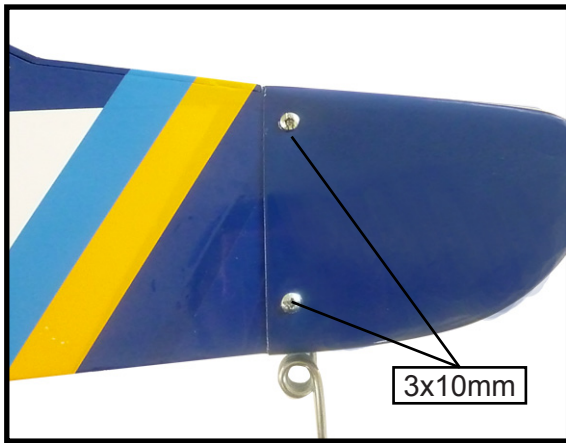

3) Install the muffler and muffler extension onto the engine and make the cutout in the cowl for muffler clearance. Connect the fuel and pressure lines to the carburetor, muffler and fuel filler valve. Secure the cowl to fuselage using the M3x10mm screws.



HORIZONTAL STABILIZER.

1) Using a ruler and a pen, locate the center-line of the horizontal stabilizer, at the trailing edge, and place a mark. Use a triangle and extend this mark, from back to front, across the top of the stabilizer. Also extend this mark down the back of the trailing edge of the stabilizer.

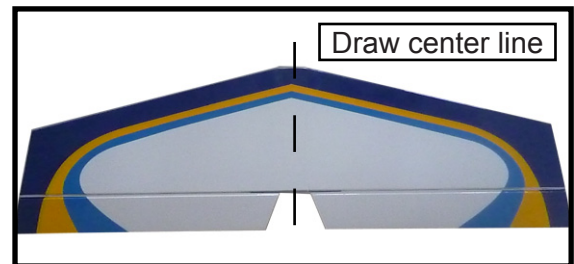

2) Using a modeling knife, carefully remove the covering at mounting slot of horizontal stabilizer.

3) Put the stabilizer into place in the position of the fuselage.

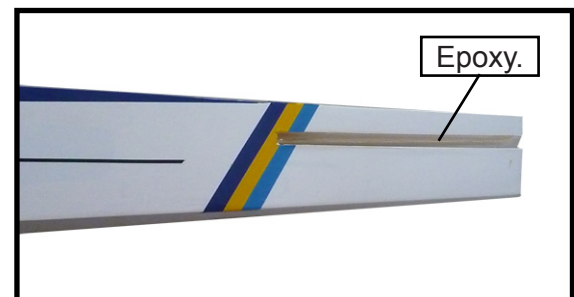

4) Install the stabilizer onto the fuselage. Align the centerline drawn on the top and the rear of the stabilizer with the centre of the fuselage. When that is aligned, hold the stabilizer in that position using T-pins or masking tape. Align the horizontal stabilizer with the wing. When viewed from the rear, the horizontal stabilizer should be level with the wing. If it is not level, use sandpaper and sand down the high side of the stabilizer mounting platform until the proper alignment is achieved. The tips of the stabilizer should also be equal distance from the tips of the wing.

5) When you are satisfied with the alignment, hold the stabilizer in place with T- pins or masking tape, but do not glue at this time.

6) With the stabilizer held firmly in place, use a pen and draw lines onto the stabilizer where it and the fuselage sides meet. Do this on both the right and left sides and top and bottom of the stabilizer.

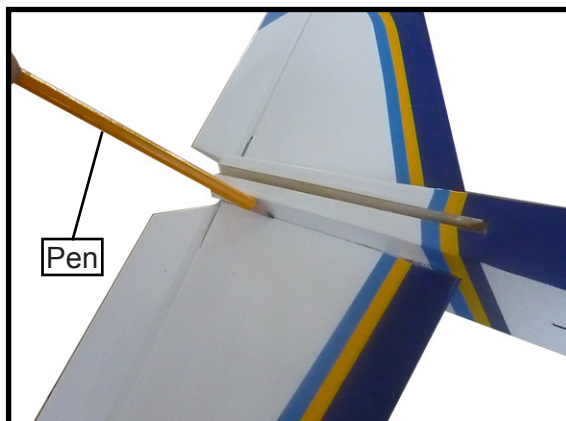

7) Remove the stabilizer. Using the lines you just drew as a guide, carefully remove the covering from between them using a modeling knife.

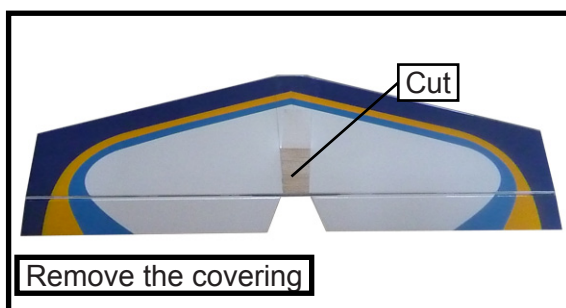

When cutting through the covering to remove it, cut with only enough pressure to only cut through the covering itself. Cutting into the balsa structure may weaken it.

8) Using a modeling knife, carefully remove the covering that overlaps the stabilizer mounting platform sides in the fuselage. Remove the covering from both the top and the bottom of the platform sides.

9) When you are sure that everything is aligned correctly, mix up a generous amount of 30 Minute Epoxy. Apply a thin layer to the bottom of the stabilizer mounting area and to the stabilizer mounting platform sides in the fuselage. Putting the stabilizer in place and realign. Double check all of your measurements once more before the epoxy cures. Hold the stabilizer in place with T-pins or masking tape and remove any excess epoxy using a paper towel and rubbing alcohol.

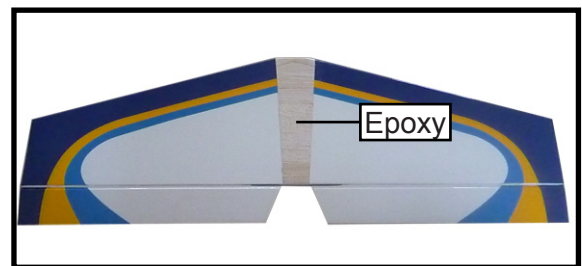

10) After the epoxy has fully cured, remove the masking tape or T-pins used to hold the stabilizer in place. Carefully inspect the glue joints. Use more epoxy to fill in any gaps that may exist that were not filled previously and clean up the excess using a paper towel and rubbing alcohol.

VERTICAL STABILIZER INSTALLATION.

1) Using a ruler and a pen, locate the center-line of the vertical stabilizer.

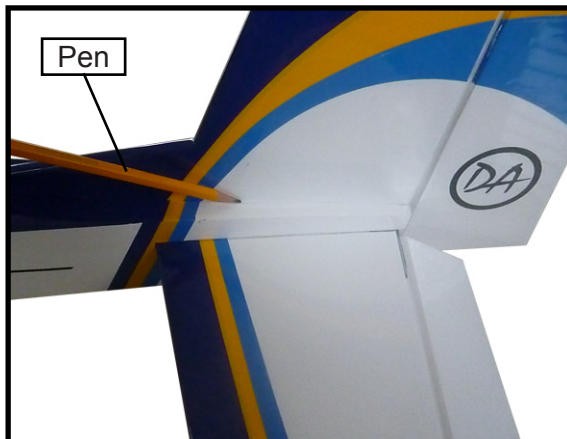

2) Using a modeling knife, remove the covering from over the precut hinge slot cut into the lower rear portion of the fuselage.

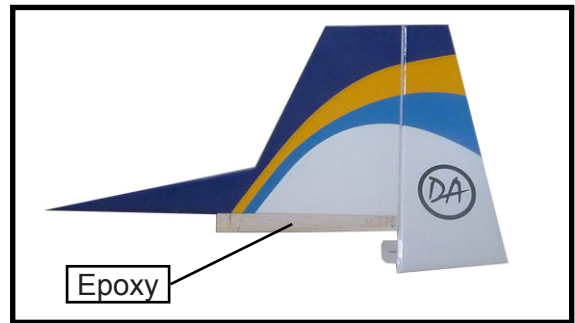
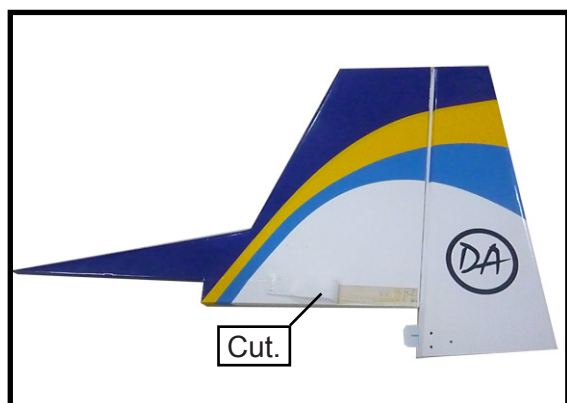
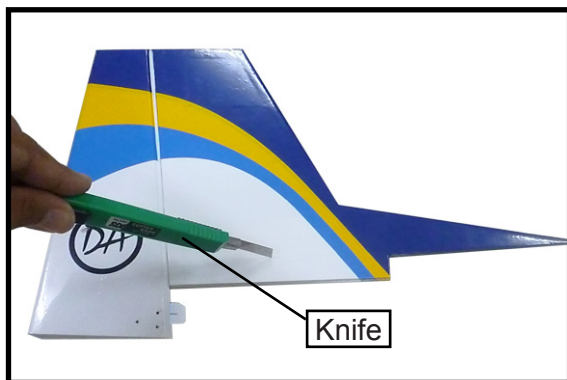

3) Slide the vertical stabilizer back in place. Using a triangle, check to ensure that the vertical stabilizer is aligned 90° to the horizontal stabilizer.

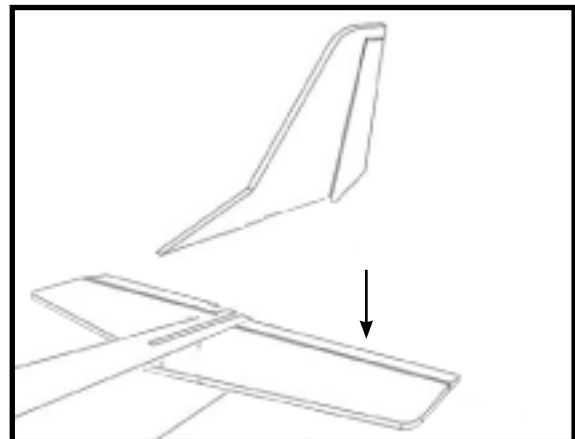

3) When you are sure that everything is aligned correctly, mix up a generous amount of Flash 30 Minute Epoxy. Apply a thin layer to the mounting slot in the top of the fuselage and to the sides and bottom of the vertical stabilizer mounting area. Apply epoxy to the bottom and top edges of the filler block and to the lower hinge also. Set the stabilizer in place and realign. Double check all of your measurements once more before the epoxy cures. Hold the stabilizer in place with T-pins or masking tape and remove any excess epoxy using a paper towel and rubbing alcohol. Allow the epoxy to fully cure before proceeding.

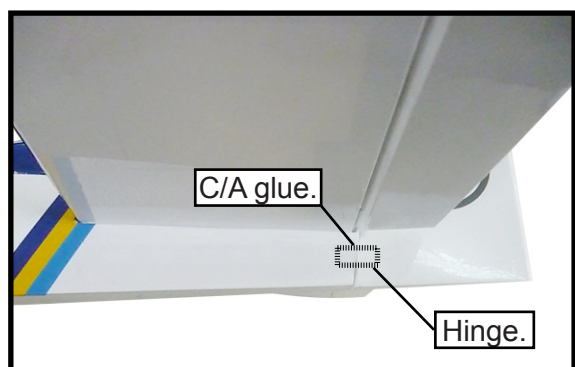



ELEVATOR - RUDDER CONTROL HORN.

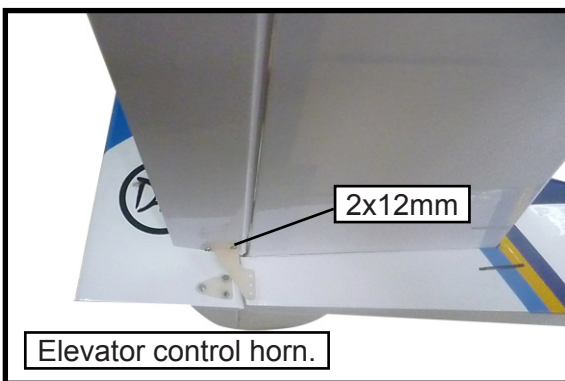
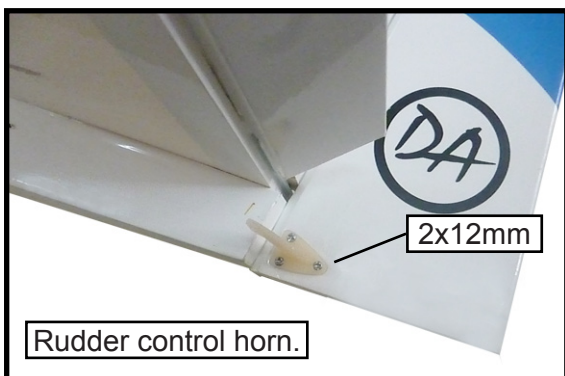
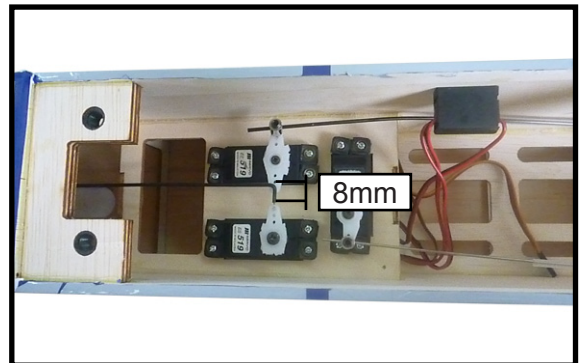
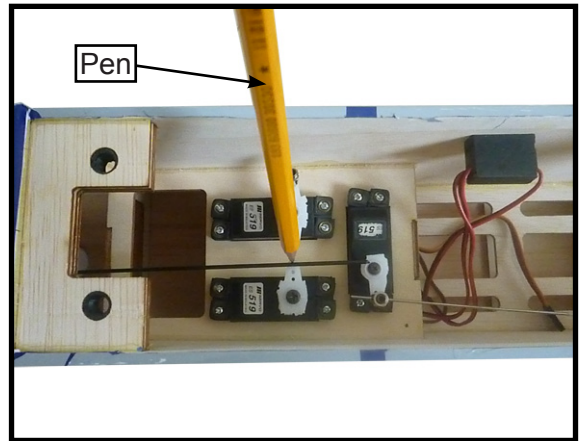

ELEVATOR PUSHROD HORN INSTALLATION.

RUDDER PUSHROD HORN INSTALLATION.

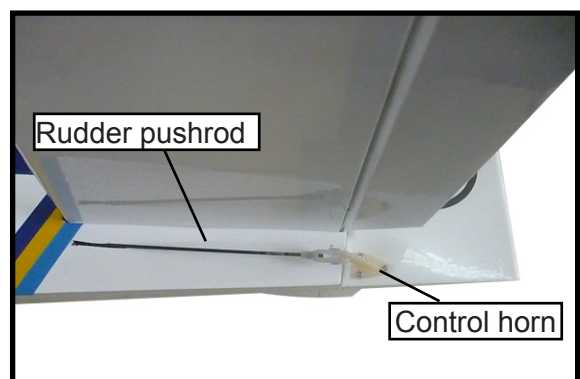
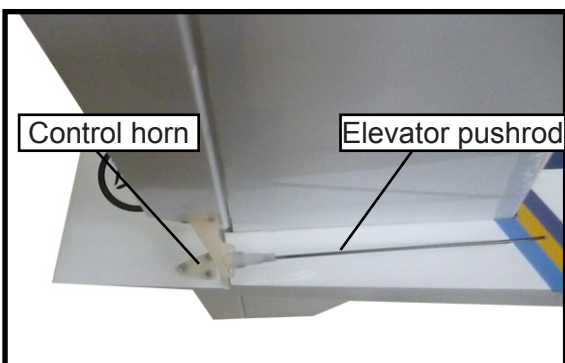

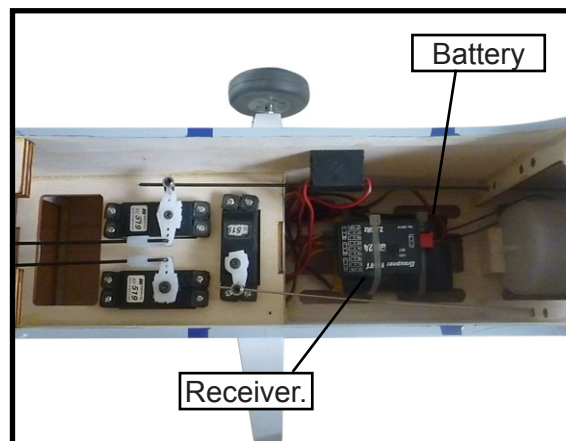
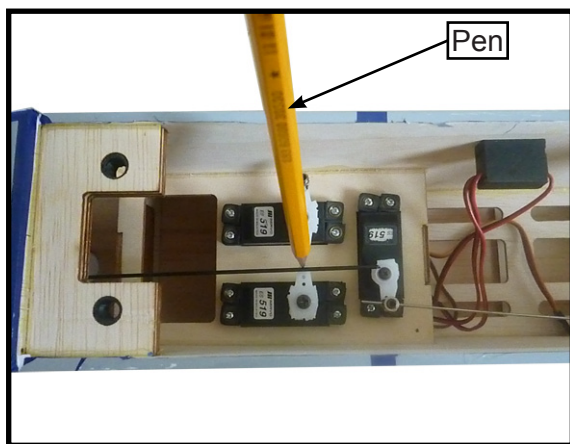

ATTACHMENT WING-FUSELAGE.

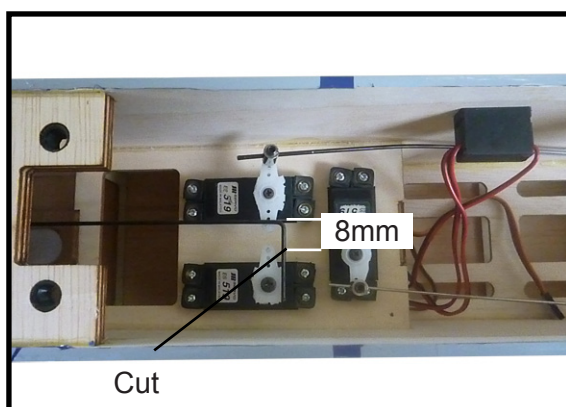

INSTALLING THE BATTERY-RECEIVER.



1) Plug the five servo leads and the switch lead into the receiver. Plug the battery pack lead into the switch also.

2) Wrap the receiver and battery pack in the protective foam rubber to protect them from vibration.

3) Route the antenna in the antenna tube inside the fuselage and secure it to the bottom of fuselage using a plastic tape.

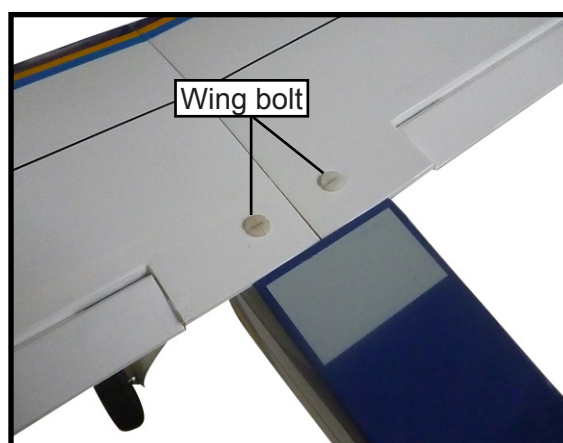

BALANCING.

1) It is critical that your airplane be balanced correctly. Improper balance will cause your plane to lose control and crash. THE CENTER OF GRAVITY IS LOCATED **70MM** BACK FROM THE LEADING EDGE OF THE WING AT THE WING ROOT.

2) Mount the wing to the fuselage. Using a couple of pieces of masking tape, place them on the top side of the wing **70mm** back from the leading edge of the wing at the wing root.

3) Turn the airplane upside down. Place your fingers on the masking tape and carefully lift the plane .

Accurately mark the balance point on the top of the wing on both sides of the fuselage. The balance point is located **70mm** back from the leading edge of the wing at the wing root. This is the balance point at which your model should balance for your first flights. Later, you may wish to experiment by shifting the balance up to 10mm forward or back to change the flying characteristics. Moving the balance forward may improve the smoothness and arrow- like tracking, but it may then require more speed for take off and make it more difficult to slow down for landing. Moving the balance aft makes the model more agile with a lighter and snappier "feel". In any case, please start at the location we recommend .

With the wing attached to the fuselage, all parts of the model installed (ready to fly), and empty fuel tanks, hold the model at the marked balance point with the stabilizer level.

Lift the model. If the tail drops when you lift, the model is "tail heavy" and you must add weight* to the nose. If the nose drops, it is "nose heavy" and you must add weight* to the tail to balance.

*If possible, first attempt to balance the model by changing the position of the receiver battery and receiver. If you are unable to obtain good balance by doing so, then it will be necessary to add weight to the nose or tail to achieve the proper balance point.

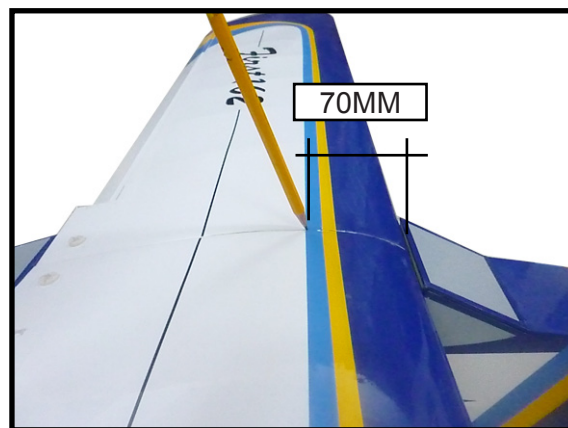

CONTROL THROWS.

Ailerons :		Rudder :	
<i>High Rate :</i>		<i>High Rate :</i>	
Up:	15 mm	Right:	20 mm
Down:	15 mm	Left:	20 mm
<i>Low Rate :</i>		<i>Low Rate :</i>	
Up:	10 mm	Right:	15 mm
Down:	10 mm	Left:	15 mm
Elevator :			
<i>High Rate :</i>			
Up:	15 mm		
Down:	15mm		
<i>Low Rate :</i>			
Up:	10 mm		
Down:	10 mm		

MAIDEN FLY.

We will not give you any instructions in this part. This is not the role of a manufacturer and it would be unrealistic and even dangerous to think we can make adjustments prior to first flight just by reading a document. It necessarily requires a minimum of experience and you must get closer to a driver or experienced trainer. This will verify the magnitude and direction of the control and various other settings. Also good battery recharging, fuel quality and other studio and field accessories.

We draw your attention to the danger of handling aircraft with electric motors. Unless it is equipped with sophisticated security, there is a very real risk of starting the engine inadvertently especially when you need to put all the radio equipment energized to start setting the servos. We recommend surrounding the propeller of a large, heavy cloth bath towel for example avoiding such injuries.

Also the recharging of lipos may pose a risk of fire or explosion. This happens when drivers hasty dangerously increase the rate of charge their batteries. The other drawback is to significantly reduce their lifespan.

To start your propulsive you must use specific start table, or any other devices provided in your club or recommended by your tutelage federation.

Never fly alone especially as our lands are often in remote locations where it is difficult to find assistance in the event of an accident.

If you follow these guidelines from the common sense you go in with a lot of fun in the world of model airplanes.

The *Direct Airscale* team wishes you good flights

 *a large Vietnamese experience for flying scale airplanes*