

## TRANSMITTER FEATURES AND FUNCTIONS

The AIRTRONICS VG400/VG600 Radio Control Systems are primarily intended for the flying of fixed wing model aircraft.

1. Retractable antenna
2. LED Scale Voltage Display
3. Control stick, horizontal-aileron, vertical-elevator (mode 2) Vertical-throttle (Mode 1)
4. Trim lever, elevator (Mode 2); throttle (Mode 1)
5. Trim lever ailerons
6. Name Plate
7. Power Switch
8. Trim lever throttle (Mode 2); elevator (Mode 1)
9. Trim lever rudder
10. Control stick, horizontal-rudder, vertical-throttle (Mode 2) Vertical-elevator (Mode 1)
11. Neck strap connecting hook
12. Servo reverse switches
13. Retract aux Channel (VG600 Only)
14. Trainer button
15. Carrying handle
16. 3 position aux channel flap switch (VG600 Only)
17. Throttle High and Low End point adjustments (VG600 Only)
18. Ail, Elev, Rud, Flap Servo Travel Adjusters (VG600 Only)

## VG400 and VG600 FM 4/6 Channel Systems

**SECTION I** Safety First for Yourself and Others.

**SECTION II** Federal Licensing Requirements and Special Operating Standards for Model Airplanes

**SECTION III** System Features

**SECTION IV** Unpacking and setting up your AIRTRONICS VG400 or VG600 Radio Control System

**SECTION V** Operation Adjustments

**NOTE: FOR BATTERY CHARGING INFORMATION AND INSTRUCTIONS ON LEARNING TO USE YOUR AIRTRONICS RADIO SYSTEM, PLEASE SEE THE AIRTRONICS RADIO OPERATION AND INSTALLATION INSERT.**

### **THANK YOU FOR SELECTING AIRTRONICS**

We appreciate your purchase of this new AIRTRONICS VG400 or VG600 Radio System.

These instructions are intended to acquaint you with the many unique features of this modern, state-of-the-art equipment. Please read them carefully so that you may obtain maximum success and enjoyment from its operation

We ask that you pay particular attention to the design of the transmitter. Notice that it has been engineered for the most natural and precise control of your choice of flying models.

Be certain to read all of the material in this manual, as well as the Operation and Installation insert.

### **SECTION I**

**SAFETY FIRST FOR YOURSELF, FOR OTHERS AND FOR YOUR EQUIPMENT.**

“Safety First” is more than just a slogan when operating radio control models. Thus, we urge, especially with respect to radio controlled aircraft that:

### **FOR YOUR SAFETY:**

Recognize that radio controlled models are not harmless toys and can be dangerous missiles if carelessly or improperly flown. You are responsible because the reliability and safe operation of the radio equipment is largely dependent upon its proper installation and utilization.

**THEREFORE, INSTALL YOUR RADIO CONTROL SYSTEM CORRECTLY AND BE CERTAIN YOU CAN FLY WELL ENOUGH TO CONTROL YOUR AIRCRAFT UNDER ALL CONDITIONS.**

**FOR THE SAFETY OF OTHERS:**

Remember that you are responsible for the safety of all spectators and in fact, everyone that may foreseeably be injured by your model.

**DO NOT FLY** where your model could injure any person or property.

**DO NOT FLY** over the heads of spectators or persons in the area of your flying field. **THIS INCLUDES** taking off, actual flight and landing. **KEEP EVERYONE**, except experienced and knowledgeable persons who are assisting you in flying, away from your model even when it is on the ground and you are preparing to fly.

**DO NOT FLY** unless and until you have an experienced instructor who has completely checked out the model and will fly the model for you and with you...until you have learned to fly competently by yourself.

Flying is a real skill that demands patience, practice and caution. **DO NOT EXPERIMENT** or run risks. Know that you can fly safely before you fly alone. The real pleasures and satisfactions come from flying or operating your model with safety and competence always in mind.

**AT THE FIELD:**

**DO NOT FLY** unless your frequency is “clear”. The transmitting signal channel (frequency) is shown on the transmitter and you must not turn on your transmitter when someone is flying or operating their model on that same frequency.

**WARNING: IF YOU DELIBERATELY OR ACCIDENTALLY TURN ON YOUR TRANSMITTER WHILE ANOTHER MODEL IS FLYING OR IN OPERATION, THAT MODEL WILL GO OUT OF CONTROL.** The same will happen to yours, so observe to see if your frequency is open before turning your transmitter on. Only one person uses a given frequency at a time. Use your channel identifier (frequency) flags for the frequency your system uses and attach the appropriate flags to your transmitter antenna. **DO OBSERVE** all the rules of the flying or operating site. The Channel and frequencies associated with them are as follows:

72 MHz (Aircraft Only)  
CHANNEL and FREQUENCY (MHz)

|    |            |    |            |
|----|------------|----|------------|
| 11 | 72.010 MHz | 31 | 72.410 MHz |
| 12 | 72.030 MHz | 32 | 72.430 MHz |
| 13 | 72.050 MHz | 33 | 72.450 MHz |

|    |            |    |            |
|----|------------|----|------------|
| 14 | 72.070 MHz | 34 | 72.470 MHz |
| 15 | 72.090 MHz | 35 | 72.490 MHz |
| 16 | 72.110 MHz | 36 | 72.510 MHz |
| 17 | 72.130 MHz | 37 | 72.530 MHz |
| 18 | 72.150 MHz | 38 | 72.550 MHz |
| 19 | 72.170 MHz | 39 | 72.570 MHz |
| 20 | 72.190 MHz | 40 | 72.590 MHz |
| 21 | 72.210 MHz | 41 | 72.610 MHz |
| 22 | 72.230 MHz | 42 | 72.630 MHz |
| 23 | 72.250 MHz | 43 | 72.650 MHz |
| 24 | 72.270 MHz | 44 | 72.670 MHz |
| 25 | 72.290 MHz | 45 | 72.690 MHz |
| 26 | 72.310 MHz | 46 | 72.710 MHz |
| 27 | 72.330 MHz | 47 | 72.730 MHz |
| 28 | 72.350 MHz | 48 | 72.750 MHz |
| 29 | 72.370 MHz | 49 | 72.770 MHz |
| 30 | 72.390 MHz | 50 | 72.790 MHz |
| 50 | 72.790 MHz | 55 | 72.890 MHz |
| 51 | 72.810 MHz | 56 | 72.910 MHz |
| 52 | 72.830 MHz | 57 | 72.930 MHz |
| 53 | 72.850 MHz | 58 | 72.950 MHz |
| 54 | 72.870 MHz | 59 | 72.970 MHz |
| 55 | 72.890 MHz | 60 | 72.990 MHz |

**WARNING:**

The frequencies allocated for model radio exclusive; however, they are in close proximity to other types of radio use in certain areas. Before operating your model check with the Federal Communications Commission (FCC) Regional Office in your area to determine whether there is a potential danger of interference from other radio users. “Outside” radio interference may cause you to lose control of your model, possibly causing injury to yourself, to others or property damage.

**SO REMEMBER:**

1. **DO NOT OPERATE** your transmitter at the field until you are certain your frequency is “clear”.
2. **DISPLAY** your frequency channel identification flag on the antenna of your transmitter.
3. **REMEMBER** that channel identifier flags do not usually state the frequency on them. Ask and be certain. If you have an eyesight limitation or defect such as color blindness for example, double check to be sure of the channel flag designations.
4. Turn your transmitter on only when you are sure no one else is using your frequency.
5. **WARNING:** Your model will go out of control and may do serious injury or damage if someone else turns on a transmitter on your frequency while you are operating your model.
6. Respect all the rules of the flying field or site.
7. At any time during the operation of your model, should you sense, feel or observe any erratic

operation or abnormality, end your flight as quickly and as safely as possible. **DO NOT** operate again until you are certain the problem has been corrected. **TAKE NO CHANCES.**

**ADDITIONAL WARNING:**

Radio controlled models are generally attractive, exciting and inviting in looks and performance. Therefore, realize that young persons, children and inexperienced adults may come within the operating range of the model, so that they may try to operate the equipment without understanding the dangers to that person or others. It is your responsibility to guard against unskilled and unknowing hands for their protection as well as for the safety of your equipment and model.

The key to R/C pleasure is the proper use of your system and all of the other model components. If you fail to follow instructions, heed the warnings given, misuse or abuse the system through improper operation or installation, the consequences will damage your system and may also mean injury to yourself, other people or property of others.

**AS TO YOUR EQUIPMENT:**

The care you give to your equipment, and its correct installation and operation, are the factors that spell either safe, successful flying or injury, damage, destruction and loss.

**ACADEMY OF MODEL AERONAUTICS (AMA)**

The Academy of Model Aeronautics is the leading national organization made up of aircraft modeling people with headquarters in Muncie Indiana. Their address is 5151 East Memorial Dr., Muncie IN 47302. We urge you to examine the benefits of the membership including liability protection in the event of certain injuries. The Academy has adopted simple and sane rules, a few which are pertinent for radio controlled flight as the **OFFICIAL AMA SAFETY CODE**; abide by these rules for your protection, the protection of others and equipment. Excerpts are as follows:

1. I will not fly my model aircraft in competition or in the presence of spectators until it has been proven to be airworthy by having been previously successfully flight-tested.
2. I will not fly my model higher than approximately 400 feet within 3 miles of an airport without notifying the airport operator. I will give right of way to and avoid flying in the proximity of full-scale aircraft. When necessary, an observer shall be utilized to supervise flying to avoid having models fly in the proximity of full-scale aircraft.

3. Where established, I will abide by the safety rules for the flying site that I use, and I will not willfully and deliberately fly my models in a careless and/or dangerous manner.
4. I will have completed a successful radio equipment ground range check before the first flight of a new or repaired model.
5. I will not fly my model aircraft in the presence of spectators until I become a qualified flyer, unless assisted by an experienced helper.
6. I will perform my initial turn after takeoff away from the pit, spectator areas, and I will not thereafter fly over pit or spectator areas, unless beyond my control.
7. I will operate my model using only radio control frequencies currently allowed by the FCC. (Only properly licensed amateurs are authorized to operate equipment on amateur band frequencies.)

**NOTE:** These basic safety precautions are for your safety, the safety of others, and of your equipment. Consider carefully all of what has been stated and obey all precautions as well as those appropriate to your particular use. Good common sense must also be used at all times in the operation of your equipment.

**STICK CONTROLS**

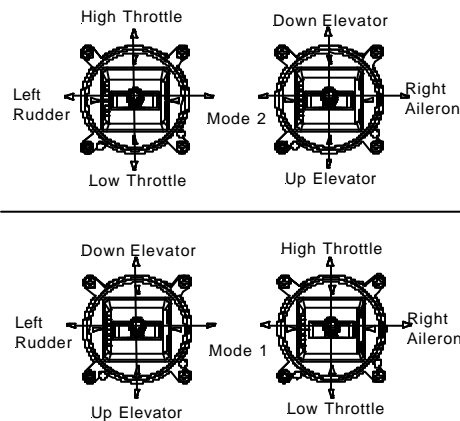

Fig 3

**SECTION II**

**FEDERAL LICENSING REQUIREMENTS AND SPECIAL OPERATING STANDARDS FOR MODEL AIRPLANES**

The Federal Communications Commission no longer requires a license to operate an R/C model transmitter.

However, the Federal Aviation Administration has announced guidelines for operation of model aircraft. We are reprinting those guidelines here and encourage your study and cooperation.

1. Purpose: This advisory circular outlines safety standards for operators of model aircraft and encourages voluntary compliance with these standards.
2. Background: Attention has been drawn to the increase in model aircraft operations, and the need for added caution in the case of free-flight and radio controlled types to avoid creating a noise nuisance or a potential hazard to full-scale aircraft and persons and property on the surface.
3. Operating Standards: Modelers, generally, are concerned about safety and do exercise good judgment when flying model aircraft. However, in the interest of avoiding undue criticism from affected communities and airspace users, **COMPLIANCE WITH THE FOLLOWING STANDARDS IS ENCOURAGED BY OPERATORS OF RADIO CONTROLLED AND FREE-FLIGHT MODELS.**
  - a. Exercise vigilance for full-scale aircraft (get other people to help if possible) so as not to create a collision hazard.
  - b. Select an operating site at a sufficient distance from populated areas to avoid creating a noise problem or a potential hazard.
  - c. Do not fly higher than 400 feet above the surface.
  - d. Do not operate closer than three miles from the boundary of an airport unless permission to do so by the appropriate air traffic control zone has been designated, or by the airport manager in the case of other airports.
  - e. Do not hesitate to ask for assistance in complying with these guidelines at the airport traffic control tower, or air route center nearest the site of the proposed operations.

Director, Air Traffic Service  
Federal Aviation Administration  
Washington, D.C.

Under SAFETY, we encouraged your participation in the Academy of Model Aeronautics as a member. Many flying fields require that you be a member of the AMA before they will allow you to use their field. They want to know that all pilots are knowledgeable concerning the AMA SAFETY CODE and through membership have the liability insurance.

### **SECTION III**

#### **SYSTEM FEATURES**

##### **TRANSMITTER**

- High Power (500 mw) internal RF Module
- Advanced Gimbal Design with control stick length and tension adjustment
- Finely ratcheted trim controls for accurate adjustment
- LED Voltage Display
- Servo reversing available on all channels

- Attractive chrome, and black plastic case with internally collapsible antenna
- Throttle High and Low End Point Adjustment
- Servo travel adjustment elev, ail, flap, rud (VG600 Only)
- Trainer system compatible with our RD6000, Radiant and other Vanguard units
- Internal Plug-in 700mah NiCd transmitter battery
- 3 Position Aux 6 channel (VG600 Only)

##### **RECEIVER**

Dual conversion 7 channel FM narrow band receiver that meets AMA guidelines for operation at 20 kHz channel spacing.

##### **SERVOS**

Both the VG400 and VG600 come with standard servos. If you need more torque and or speed, we have many servos to choose from.

##### **ASSEMBLY OF CHANNEL IDENTIFER:**

Your Airtronics channel identification plaques and flag are assembled to the holder as indicated in Figure 5. Note that the plaque holder is installed on the antenna so that it will not slide down the antenna.



Figure 5

### **SECTION IV**

#### **UNPACKING AND SETTING UP YOUR AIRTRONICS VG400/VG600 FM RADIO CONTROL SYSTEM**

The packaging of your AIRTRONICS radio control system was especially designed for the safe transportation and storage of the components. **DO NOT DISCARD THESE CONTAINERS** as they can be used for storage or returning equipment for repair.

We recommend the following procedure to familiarize yourself with the components of your system and as preparation for installation in your model.

1. Remove the transmitter from the package box.
2. Affix frequency channel identifier plaques to the transmitter as shown in picture below.
3. Charge the receiver and transmitter batteries as stated in the Installation and Guidelines Manual. **DO NOT QUICK CHARGE BATTERIES AT ANY TIME.**
4. Switch on the transmitter and note the LED display meter indicating the unit is operating. The LED display will light up and indicate the state of charge of the internal NiCd battery pack. Plug in the AC charger in the wall outlet and connect the proper leads in the transmitter and receiver battery and let charge for a full 24 hours for the first initial charge. After both batteries are fully charged, note the LED display to make sure that the FULL light is operating properly. If the FULL LED will not light up after a 24-hour charge, your transmitter RF output maybe weak, this will need to be sent to AIRTRONICS to be checked.
5. Switch "off" the transmitter and remove all of the other components from the foam packing box containing your AIRTRONICS VG400/VG600 FM radio control system.
6. Figure 2 shows how to connect the components of your system together. Note the servo and switch harness plugs are inserted in the receiver. This will allow you to switch the receiver battery on and or off. At this point, your objective is to get the system operating on your workbench. Once connected, you must then refer to the corresponding diagram for your system (Figure 3), showing the transmitter control stick's function.

**WARNING:** Do not attempt to use the transmitter if the LED lights are not visible from MID to Full.

**CAUTION:** IF NO LIGHTS ARE VISIBLE WHEN YOU TURN THE TRANSMITTER SWITCH ON, THE BATTERY PACK WITHIN THE TRANSMITTER IS MORE LIKELY DISCHARGED. CHARGE THE BATTERIES AS OUTLINED UNDER SECTION IV BATTERY CHARGING, IN THE INSTALLATION AND GUIDELINES MANUAL.

**REMEMBER THAT IF A TRANSMITTERS PERFORMANCE HAS DROPPED IT MAY FAIL TO SEND THE SIGNALS NECESSARY TO ADQUATELY AND SAFELY CONTROL THE MODEL RESULTING IN A POSSIBLE CRASH.**

**TAKE THE TIME TO LEARN THE NAMES OF ALL COMPONENTS YOU ARE GOING TO CONNECT AND TO IDENTIFY ALL OF THE TRANSMITTER**

**CONTROL STICK'S FUNCTIONS AND NAMES ATTACHED TO THOSE FUNCTIONS.**

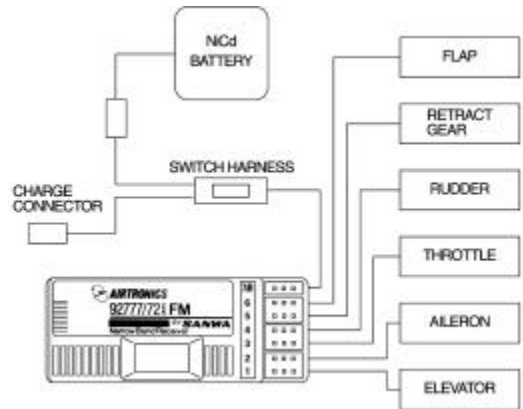

**NOTE THE FOLLOWING AT THIS POINT:**

It is of no consequence at this point which servo you plug into which function since your aim is simply to learn and see how the system operates on your bench. The correct channel outputs are indicated on the receiver case.

The connectors on your AIRTRONICS radio control system are rugged but should be handled with care. The receiver that came with your unit is designed for the new "Z" connector servos only. The older AIRTRONICS connectors will not work with this new system. You must use a connector plug adapter part #99400Z in order to use older AIRTRONICS servos, switch harness and or batteries.

**WARNING:** IF YOU CONNECT OLDER AIRTRONICS SERVOS AND OR BATTERIES WITHOUT USING THE CORRECT ADAPTER, YOU MAY SHORT OUT YOUR SYSTEM AND CAUSE MAJOR DAMAGE TO YOUR FLIGHT PACK. SHORTED SYSTEMS WILL NOT BE COVERED UNDER ANY WARRANTY.

Do not attempt to force the servo plugs into the receiver; properly align each plug and it will move into place. The same is true of the plug leading from the receiver battery pack and switch harness.

1. Once you have followed the diagrams for connecting the airborne components of your VG400/VG600 FM radio control system and you have studied and understood the diagram illustrating the transmitter control stick functions, you are ready to energize the system and study its actual operation.
2. Switch on the transmitter, then switch on the airborne package. The system is now energized. There may be some initial movement in the servos even though you have not moved the transmitter sticks. **THIS IS NORMAL.** Once they have found a position, they will stay there.
3. Now follow the diagram indicating the transmitter's control functions by moving each stick and watching the reaction of the servo or servos. Move the small black trim levers and note the slight servo movements. Keep these all centered through the installation of your system in your model. They will be used in actual flight or operation of the model to adjust servo position slightly...a process called "trimming". If the airborne system fails to operate, charge the battery pack as outlined in the Battery Charging Section of Installation and Guidelines.
4. Switch off the receiver, then switch off the transmitter. **GET USED TO THIS SEQUENCE:** When turning the system off, **TURN THE RECEIVER OFF FIRST, THEN THE TRANSMITTER.** When turning the system on, the proper sequence is to **TURN ON THE TRANSMITTER THEN THE RECEIVER.**

## **SECTION V**

### **FOR OPERATION AND ADJUSTMENTS**

**FOR SAFE AND SUCCESSFUL OPERATION OF YOUR RADIO CONTROL MODEL, IT IS IMPORTANT TO CAREFULLY FOLLOW THE INSTRUCTIONS BELOW AND OBTAIN TRAINING IN THE OPERATION OF YOUR MODEL FROM A WELL-EXPERIENCED INDIVIDUAL.**

At this point, having followed all of the instructions, directions and guidelines contained in the earlier sections of this manual and having completed your model and installed your VG400/VG600 system observing the directions and guidelines contained in the separate manual entitled "FUNDAMENTALS AND GUIDELINES FOR INSTALLATION OF YOUR AIRTRONICS SYSTEM". We present here general instructions concerning the process of learning to use your VG400/VG600 System. Most of what is stated is directed toward those using the system in a powered model aircraft. However it is equally applicable to sailplanes.

It should be re-emphasized that before you make initial use of your completed model, you should have one or more persons who are thoroughly experienced in the field of radio controlled modeling completely go over the model prior to your use to make certain you have properly installed your VG400/VG600 system and followed all of the directions given in this manual as well as the Instruction Manual. We recommend that the individual(s) who are "checking out" your model be shown these two manuals and that you and they review all of the materials contained in them to make certain that you have followed all directions and guidelines and understand the warnings that have been given. This should be done even if you are obtaining flight training from experienced and competent flyers.

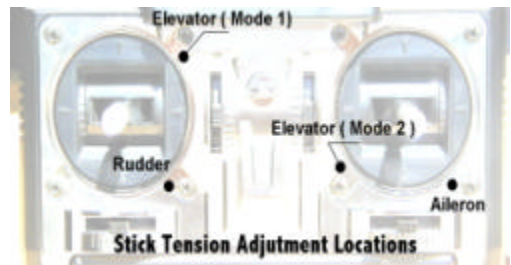

### **SERVO REVERSING:**

The VG400/VG600 FM transmitters include servo reversing on all channels. This feature makes it possible to select the direction of the servo rotation of the channels. Consequently, servo installation is greatly simplified and the direction of the servo rotation becomes unimportant. The servo reversing switches are located in the front center of the transmitter faceplate.

### **THROTTLE END POINT ADJUSTMENT:**

Both VG400 and VG600 have a new feature that will allow you to set the high and low-throttle end points. By moving the throttle stick to high-throttle, you can adjust the TH-H adjustment clockwise to increase servo travel or counter clockwise for less travel. For low-end adjustment you will use the same sequence as just stated but set the throttle stick to low throttle and use TH-L adjuster.

### **SERVO TRAVEL VOLUME ADJUSTMENT (VG600 Only)**

This new feature will allow you to adjust servo travel for Aileron, Elevator, Aux Flaps and Rudder. Moving the adjuster clockwise will increase total servo travel. Moving the adjuster counter clockwise will decrease total servo travel. This is very useful when setting up a model for the first flight or you find you need more or less control for the model aircraft.

NOTE: Turning all adjusters clockwise will give 100% maximum servo movement.

#### PLUG-IN CRYSTALS:

Your VG400/VG600 FM transmitter and receiver feature plug-in crystals for ease of manufacture. The owner should not change the FM crystals because realignment of the transmitter and receiver FM deviation is required following a crystal change. Failure to do this could cause the transmitter signal to be outside of the receivers pass band. This could cause loss of control and a subsequent crash of your model. Do not change crystals! If a change of operating channel is desired, return the VG400/VG600 transmitter and receiver to Airtronics for the desired channel change. Channel changes are not covered under warranty and a service charge will apply.

#### CONTROL STICK LENGTH AND TENSION ADJUSTMENT:

The length and spring tension of the control sticks can both be adjusted as required by the individual flyer. Both procedures are simple.

For stick spring tension, turning the adjustment screw clockwise will increase stick tension. Turning the adjustment screw counter clockwise will decrease or soften stick tension. See picture below for adjustment locations.

Adjusting the control stick length is even easier. To do so, hold Part B with the fingers and unscrew Part A counter clockwise to loosen the two pieces. Now screw Part A in or out to the desired position and lock it in place by screwing Part B against it. It is recommended that at least four threads be left inside Part A at its longest length for best results.

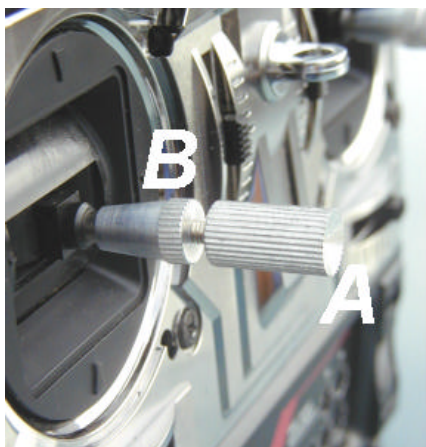

#### MASTER/TRAINER SYSTEM:

The VG400/VG600 FM transmitters have a Master/Trainer (M/T) capability. This allows you to connect another transmitter by use of the Airtronics Training System Cable Part 97100. The expert-level flyer modeler can therefore assist the beginner in learning how to fly. See the list below for compatible transmitters.

- VG400
- VG600
- Radiant
- RD6000
- Vanguard All

To use the Master/Trainer capability, plug the trainer system cable into both transmitters. The transmitter that is designated as the Master must match the receiver in use. For the following instructions, the Master transmitter is designated as #1 and the student transmitter will be referred to as #2.

Turn on #1 transmitter and the model receiver switch. Note the position of the control surfaces on the aircraft. The #2 transmitter switch must be in the "OFF" position, since its encoder receives its power from the #1 transmitter. Push and hold the trainer button #14 on #1 transmitter. #2 Transmitter now has control of the model. Move the control sticks in the proper direction. You can now check the neutrals of #2 transmitter to insure they correspond to master #1 transmitter. By turning "On and Off" the trainer button, you can see if the #2 transmitter trims need to be adjusted. Adjust the trims on #2 transmitter only, moving the trims on #1 transmitter will cause the aircraft to be off trim. This procedure is done after the aircraft has made its first trim flights.

**CAUTION: REMEMBER THAT #2 TRANSMITTER POWER SWITCH MUST BE KEPT IN THE OFF POSITION.**

**IT IS IMPERATIVE THAT ONLY AN EXPERIENCED PILOT HELP WITH THE TRAINING OF THE STUDENT ON #2 TRANSMITTER.**



1185 Stanford Court, Anaheim, CA. 92805

Tel: (714) 978-1895

FAX: (714) 978-1540

[www.Airtronics.net](http://www.Airtronics.net)